

# ball joints axial and rod eyes

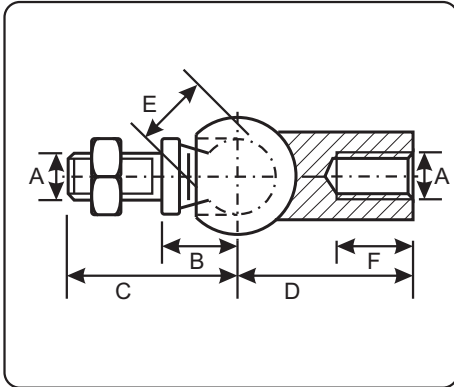

## ball joints axial according to DIN 71802

material: steel, zink plated  
(not to be used for gas pull springs !!)

part-number	A	B	C	D	E	F	max.pull-force
98.590	M 5	10	20	22	8	10	25 N
98.600	M 6	11	23,5	25	10	11,5	40 N
98.610	M 8	13	29,5	30	13	14	60 N
98.620	M10	16	36	35	16	15,5	80 N
98.630	M14X1,5	20	48	45	19	21,5	100 N

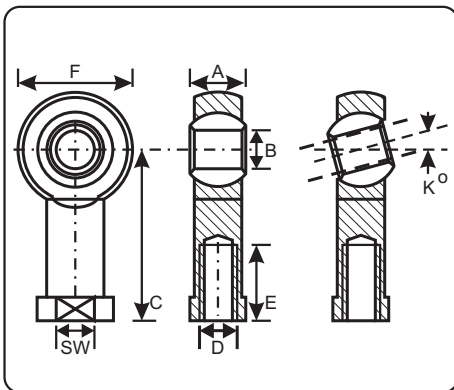

## rod heads

: female taper thread, maintenance free  
: bearing: steel with PTFE  
: long life  
: for stainless steel see page E61

part-number	A	B	C	D	E	F	K	SW
96.090	8	5	27	M 4 !!	10	18	13	9
96.100	9	6	30	M 6	12	20	13	11
96.110	12	8	36	M 8	16	24	13	13
96.120	14	10	43	M10	20	28	13	17
96.125	16	12	50	M12	22	32	13	19
96.130	19	14	57	M14	25	36	15	22

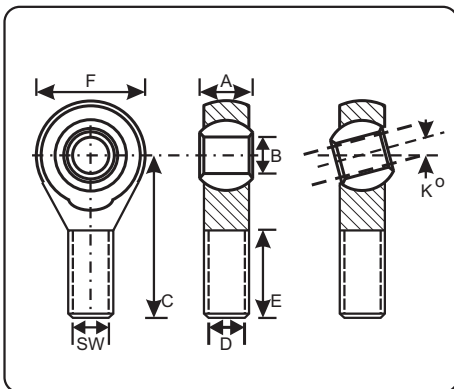

## rod heads

: with male thread  
: completely maintenance free  
: bearing: steel with PTFE  
: long life

part-number	A	B	C	D	E	F	K
96.200	9	6	36	M 6	22	20	13
96.210	12	8	42	M 8	25	24	13
96.212	14	10	48	M10	29	28	13
96.214	16	12	54	M12	33	32	13
96.216	19	14	60	M14	36	36	15

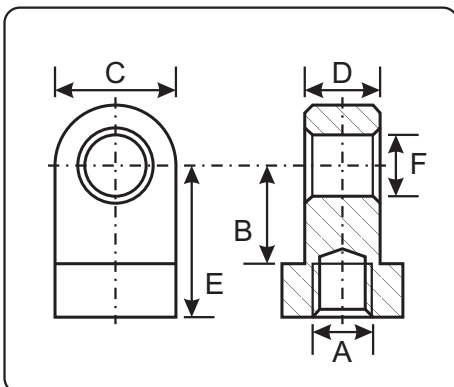

## eyelet

: material: steel, zink plated  
: for stainless steel see page E61

part-number	A	B	C	D	E	F
98.765	M 8	13	14	10	20	8
98.795	M10	17	18	10	30	8